

VANDE HEY RALEIGH DIAMOND SHINGLE INSTALLATION GUIDELINES

DESCRIPTION: Vande Hey Raleigh Diamond Shingle

MATERIALS:

Diamond Shingle: The roofing shingle is a copper shingle made of 16 oz (.45kg) cold rolled copper. The shingles consist of exposed surface area and a head lap for fastening. The tile has a width of 15" (381mm) and a height of 14¾" (374.7mm). The exposed shingle area has a total width of 12" (304.8 mm) and a height of 12" (304.8 mm). The shingle is stamped with a decorative detail in the center of the shingle. Each shingle has an approximate weight of 1.9 lbs (.86kg) and the shingles installed weight is 190 lbs (8.6kg) per 100 sq ft. Hip and ridge flashing supplied by Vande Hey Raleigh are manufactured from the same material as the shingles.

FASTENERS:

Copper Diamond Shingles: Shingles shall be fastened with 11 gauge ring shank copper nails 1" (25.4 mm) long.

Underlayment: Fasteners for underlayment shall be 11 gauge roofing nails with ⅜" (9.5 mm) heads, with sufficient length to penetrate into the sheathing ¾" (19.1 mm) or through the sheathing, whichever is less.

Flashing: Flashings shall be fastened with 11 gauge ring shank copper nails with sufficient length to penetrate the sheathing ¾" (19.1 mm) or through the sheathing, whichever is less.

Hip/Ridge Flashing: Fasteners for hip/ridge flashing shall be No. 10 coarse thread corrosion resistant pan head sheet metal screws with neoprene washers 2" (63.5 mm) in length.

UNDERLAYMENT:

Underlayment: Underlayment shall consist of one layer No. 30 Asphalt Saturated Organic Felt to meet requirements of ASTM D-226, Type 2 or equal.

Flashings: Flashings shall be 16 or 20 oz (.45 or .56kg) copper. Flashings shall comply with the applicable code and Vande Hey Raleigh installation instructions.

Sealants: Sealants to seal hip and ridge flashing should be high quality sealants, to meet or exceed requirements of U.S. TT-S-00230C, U.S. Fed Cat. No 8030-965-2397, Canadian 19-GP-5M ASTM C290-79 or equal.

INSTALLATION:

General: The shingles shall be installed directly to the roof deck. The shingles are to be installed over code complying, minimum 15/32" (11.9 mm) exterior grade plywood at a minimum slope of 4:12.

Underlayment is installed parallel to the roof eave with a 6" (152.4 mm) lap on the ends and a 3" (76.2 mm) side lap. The underlayment is fastened with sufficient length fasteners spaced at 6" (152.4 mm) on center at the side laps and 3" (76.2 mm) on center at the end laps.

The shingles are secured to the sheathing using 3 fasteners through the pre-punched holes. Exposure of the shingles are 12" (304.8 mm) X 12" (304.8 mm). Shingles are installed after grids of lines are snapped on the roof deck. The first line is snapped horizontally at 12" (304.8 mm) from the edge of the eave metal and then 8½" (215.9 mm) horizontally up the remainder of the roof. Vertical lines are then snapped 8½" (215.9 mm) on center starting in the center of the roof and working left and right. The shingles are then installed starting in the center and working left and right. (Fig 6)

Severe Climate Areas: For areas where the average daily temperature in January is 25° F (-4° C) or less, and other areas designated by Vande Hey Raleigh or the building official, or where there is a possibility of ice forming along the eaves, causing a backup of water, a self seal membrane extending from the eave's edge to a point at least 24" (609.6 mm) inside the exterior wall line of the building is to be used. Also install a 3' (914.4 mm) wide self seal membrane lapped 3" (76.2 mm) and sealed to each side of the valley flashing, before installing the horizontal underlayment.

Valleys, Sidewalls and Headwalls, Hips and Ridges: Valleys (Figure 4), sidewalls (Figure 7) and headwalls (Figure 8) are to be flashed and hip and ridge flashing (Figures 3 & 6) is to be installed in accordance with the applicable building code and the manufactures installation instructions. The hip and ridge flashing is to be installed using a continuous cleat with non-corrosive screws and neoprene washers, fastened 12" (304.8 mm) on center (Figures 3 & 6). A sealant is used at overlaps on flashings.

TECHNICAL DATA

<u>STYLE</u>	<u>DIMENSIONS</u>	<u>SHINGLES PER SQUARE</u>	<u>EXPOSURE PER SHINGLE</u>	<u>APPROX LBS PER SQUARE</u>	<u>APPROX KGS PER SQ MTR</u>	<u>APPROX SQS PER PALLET</u>
Diamond Shingle	14¾" x 15"	100	12" x 12"	190 lbs	9.3	8

All shingles are tested in accordance with and exceed minimums for strength, water absorption, freeze-thaw, dimensions and installed weight. Approvals are pending.

◇ **ICCES – pending**

Laying pattern: Laid from left or right starting in the center.

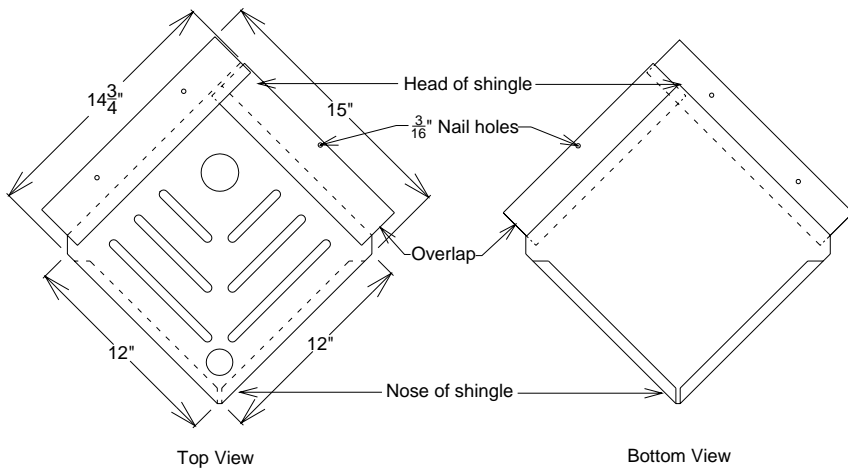

Figure 1 - Diamond Shingle

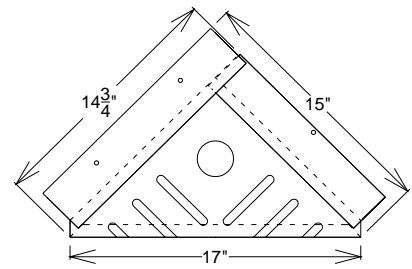

Figure 2 - Diamond Shingle Starter

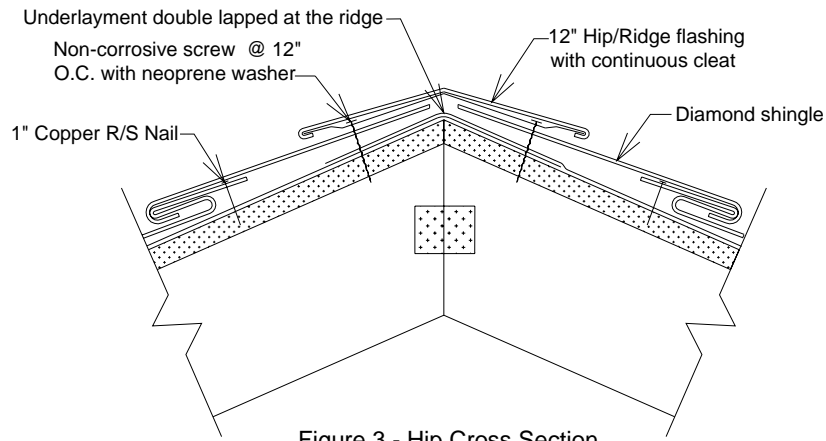

Figure 3 - Hip Cross Section

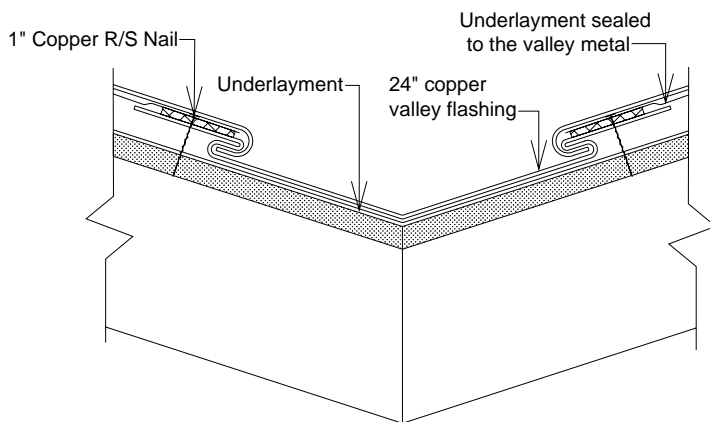

Figure 4 - Valley Cross Section

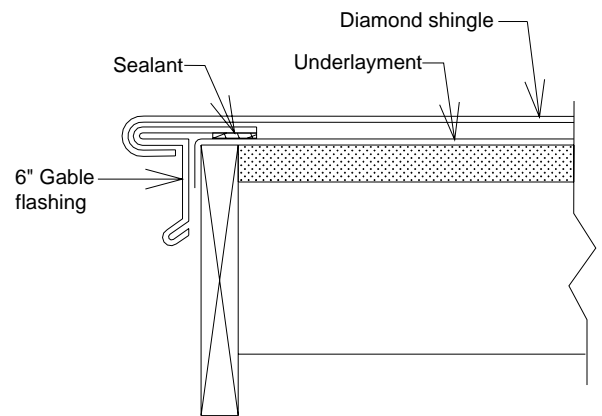
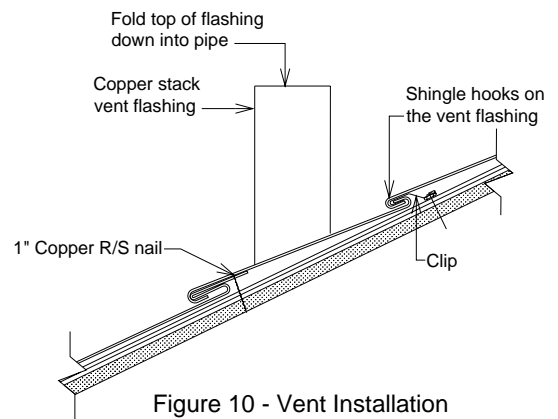
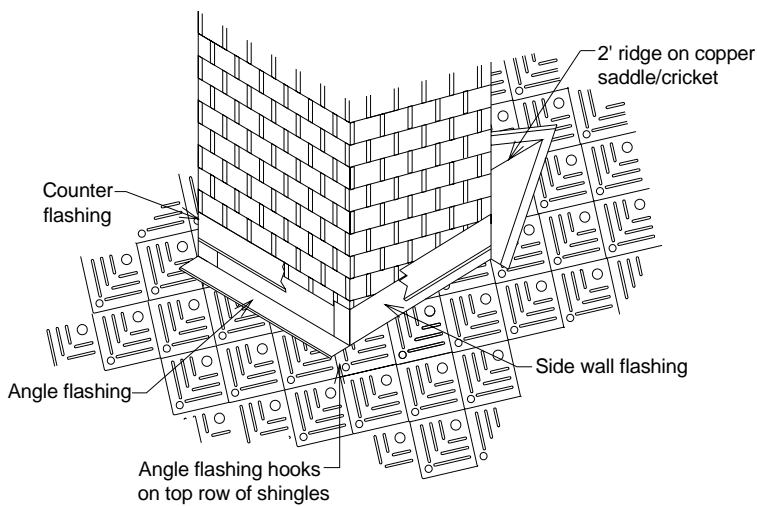
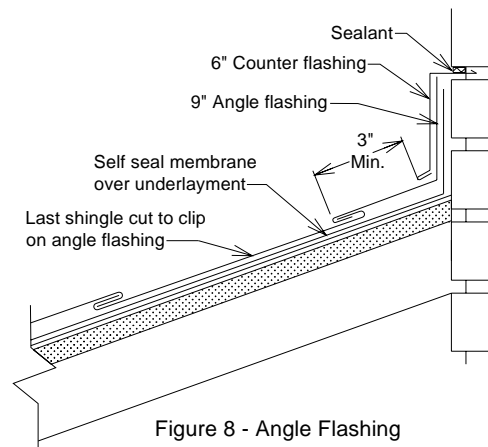
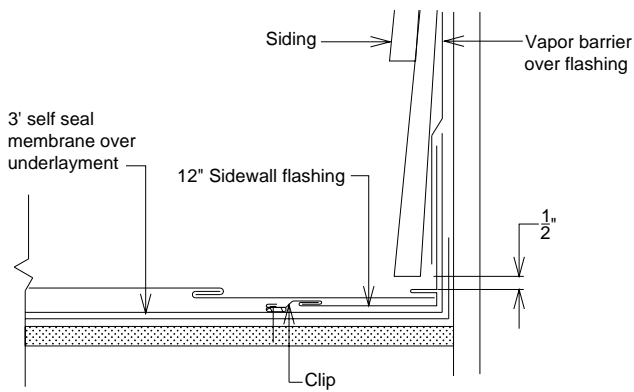
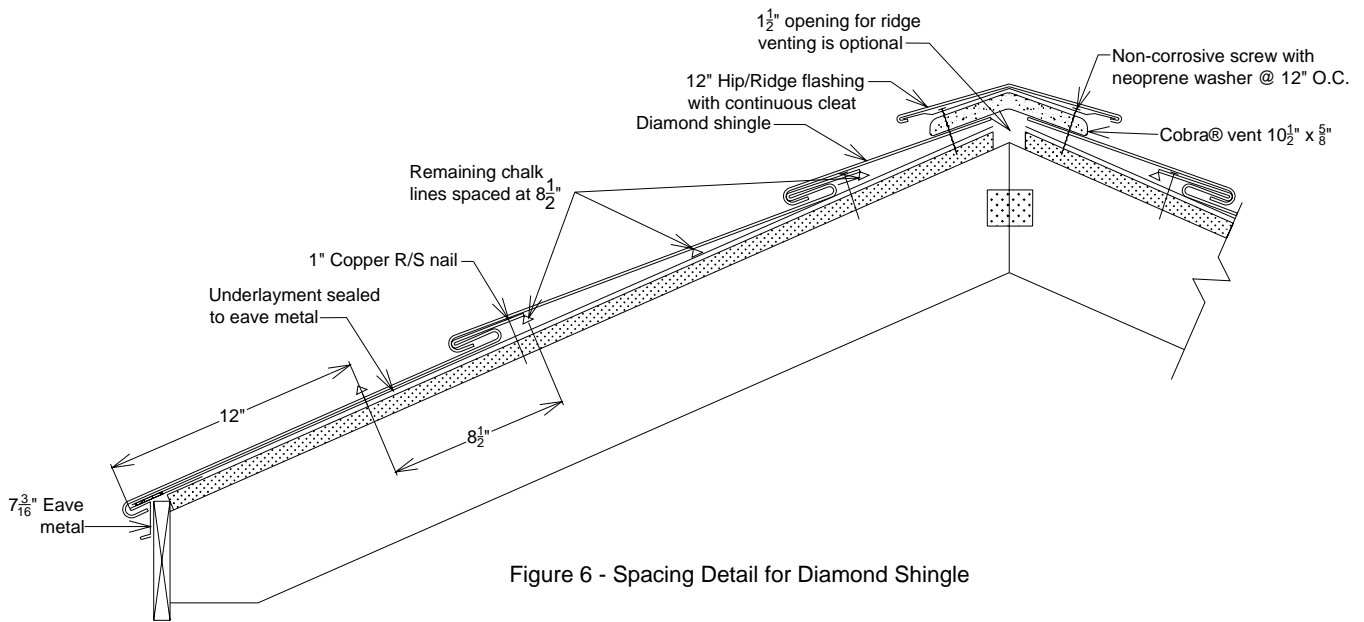

Figure 5 - Gable Cross Section



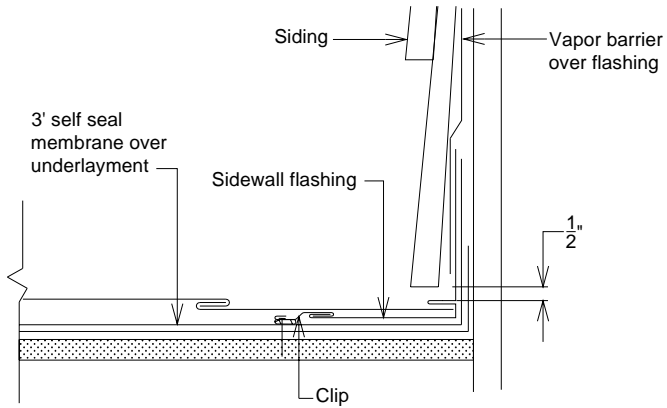

Figure 8 - Sidewall flashing

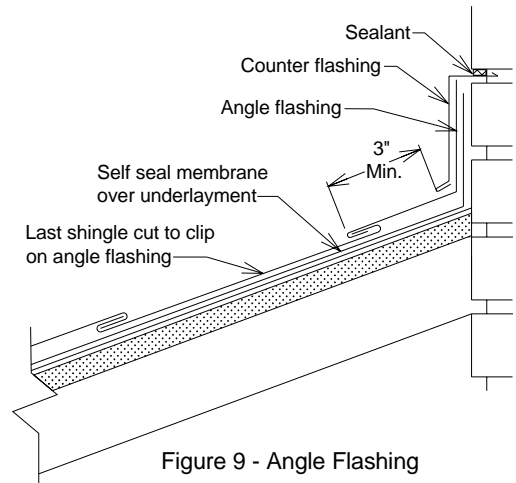

Figure 9 - Angle Flashing

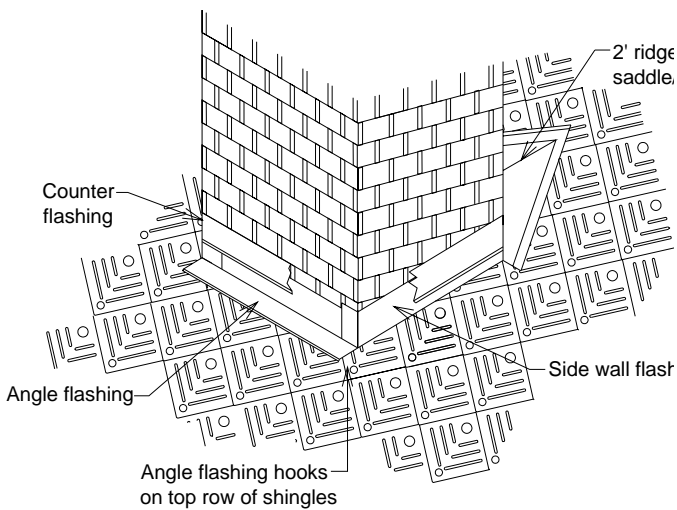

Figure 10 - Chimney Flashing Detail

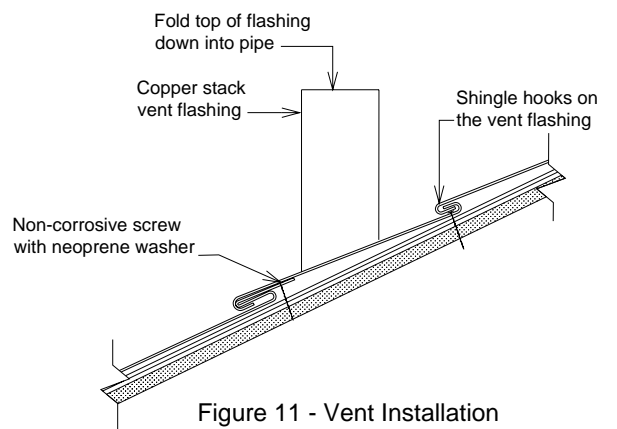

Figure 11 - Vent Installation